

Center Hanger Load Cell

Reyco 21B Trailer Applications



Our center hanger style load cells are built to withstand the toughest environments. Designed to be used on Reyco 21B trailer suspensions

Center Hanger Load Cell 8300855-33



Key Features:

- Extremely Durable
- Alloy steel, high resistance to corrosion
- Triple redundant sealing
- 4 Pin pigtail - 3ft
- Temperature compensated
- Extremely accurate and reliable in the harshest environments.
- Completely sealed internal electronics

Applications:

- Forestry/logging
- Bulk hauling
- Aggregate
- Agriculture
- General highway
- Refuse

5920 South 194th Street | Kent, WA 98032 | USA
Sales Support: 800-638-5111 | Technical Support: 626-202-5047
E-mail: Obw.usa@vpgsensors.com

sionboard.com



Center Hanger Load Cell 8300855-33

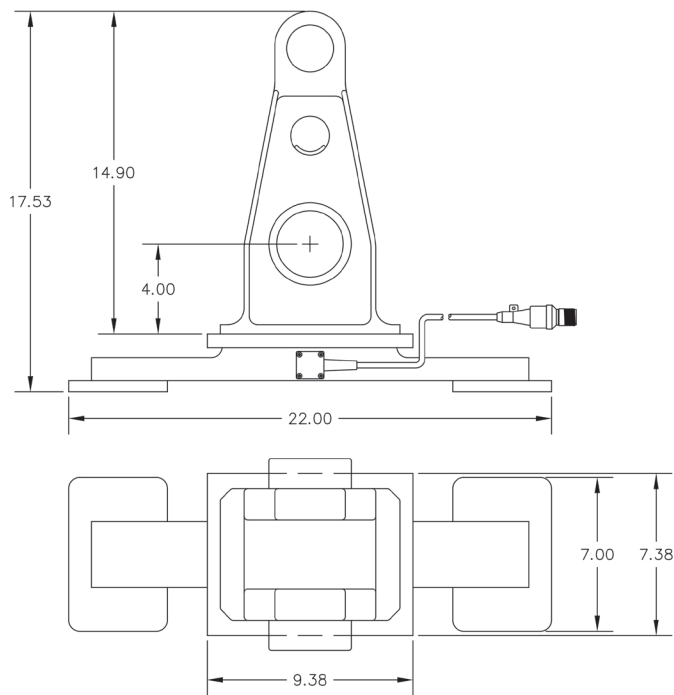

Specifications

PARAMETERS	VALUE
Static Capacity	30,000 lbs (13,608 kg)
Dynamic Capacity	15,000 lbs (6,804kg)
Maximum Safe Load	200% of static capacity
Output	0.600 mV/V at 15,000lbs
Non-linearity, Hysteresis Repeatability	± 0.1% of full scale
Creep	± 0.1% of load in 20 minutes
Temperature Compensated Range	14° to 104°F (-10° to 40°C)
Temperature Operating Range	-40°F to 150°F (-40°C to 65°C)
Maximum Excitation	15V dc or ac
Impedance	350Ω min.
Isolation Resistance	500MΩ at 50V
Load Cell & Bearing Plate Material	ASTM A514 (T1) Steel
Unitized Weight	73lbs (32.9kg)

DISCLAIMER: ALL PRODUCTS, PRODUCT SPECIFICATIONS AND DATA ARE SUBJECT TO CHANGE WITHOUT NOTICE. Vishay Precision Group, Inc., its affiliates, agents, and employees, and all persons acting on its or their behalf (collectively, "VPG"), disclaim any and all liability for any errors, inaccuracies or incompleteness contained herein or in any other disclosure relating to any product. The product specifications do not expand or otherwise modify VPG's terms and conditions of purchase, including but not limited to, the warranty expressed therein. VPG makes no warranty, representation or guarantee other than as set forth in the terms and conditions of purchase. **To the maximum extent permitted by applicable law, VPG disclaims (i) any and all liability arising out of the application or use of any product, (ii) any and all liability, including without limitation special, consequential or incidental damages, and (iii) any and all implied warranties, including warranties of fitness for particular purpose, non-infringement and merchantability.** Information provided in datasheets and/or specifications may vary from actual results in different applications and performance may vary over time. Statements regarding the suitability of products for certain types of applications are based on VPG's knowledge of typical requirements that are often placed on VPG products. It is the customer's responsibility to validate that a particular product with the properties described in the product specification is suitable for use in a particular application. You should ensure you have the current version of the relevant information by contacting VPG prior to performing installation or use of the product, such as on our website at vpgsensors.com. No license, express, implied, or otherwise, to any intellectual property rights is granted by this document, or by any conduct of VPG. The products shown herein are not designed for use in life-saving or life-sustaining applications unless otherwise expressly indicated. Customers using or selling VPG products not expressly indicated for use in such applications do so entirely at their own risk and agree to fully indemnify VPG for any damages arising or resulting from such use or sale. Please contact authorized VPG personnel to obtain written terms and conditions regarding products designed for such applications. Product names and markings noted herein may be trademarks of their respective owners.